



# 6235-C/6235A-C

## SOFT SERVE FREEZER

Two Flavor, Countertop, Digital Control  
A: Pump Feed Model



### Powerful and Versatile

Two flavor medium capacity countertop model for ice cream, frozen yogurt and much more

#### Fast Freeze Down

Patented high efficiency heat exchanger allows fast freeze down with low energy consumption

#### Digital Control and Display

Microprocessor control provides access to system settings and additional functions. Digital interface displays critical info as system status, temperatures, dispense count, errors, etc.

#### Auto Programming

Allows automatic switching of operation modes based on preset schedules

#### Standby

Maintains product temperature in both mix hopper and freezing cylinder below 4.4°C (40°F) overnight

#### Hopper Agitator

Maintain product consistency and prevent product separation

Ideal for medium capacity outlets to serve ice cream, frozen yogurt, gelato or sorbet.

Fully loaded with all standard options.

#### Soft System Start

Slow motor start reduces equipment noise and stress on drive train

#### Direct Drive Transmission

Eliminates consumable moving parts and increases transmission efficiency

#### Defrost for Cleaning

Increases efficiency during cleaning by heating frozen product in cylinder

#### Quick Freeze

Turn on freeze immediately to freeze down to serving viscosity when quick service is required after long idle period

#### Self Closing Valve with Speed Control

Automatically prevents product overflow after dispense; Provides flexibility in dispense rate control

#### Safety Protections

- Low temperature and motor overload shutoffs to protect in the event of cylinder freeze up
- High pressure switch to prevent compressor overheating



# 6235-C / 6235A-C

# SOFT SERVE FREEZER

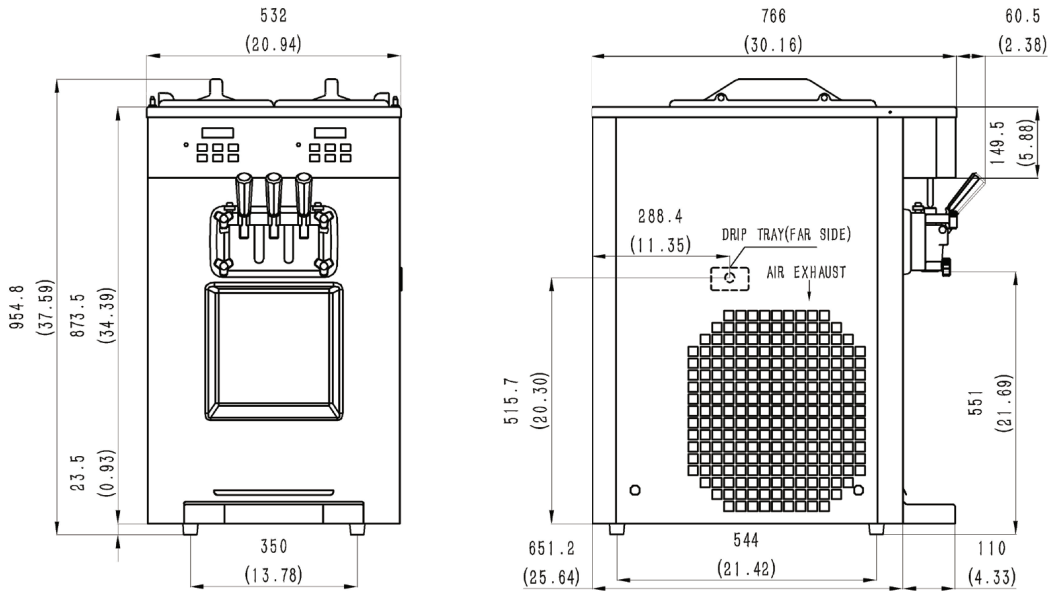

## SPECIFICATIONS

Flavors	2 + Twist
Freezing Cylinders	2 x 1.7L / 1.8qt
Mix Hoppers	2 x 12L (8L for A)
Output Capacity (80 grams)	450 serves/hr
Clearance Requirements	152mm/6" on left

## Weight

	Kg/lb (Gravity)	Kg/lb (Pump)
Net	186 / 410	196 / 432
Shipping Cylinders	200 / 441	210 / 463
Volume	0.54 CBM / 19.08 CBF	

## Dimensions

	Net (mm/in)	Shipping (mm/in)
Width	532 / 20.9	610 / 24.0
Depth	651 / 25.6	805 / 31.7
Height	977 / 38.5	1100 / 43.3

## Electrical

Electrical	Fuse	Amps	Power(kW)
220-240/50/1	25	17	3.3
208-230/60/1	25	18	3.6

## FEATURES

Control System	Double, Digital
Refrigerated Hopper	✓
Hopper Agitator	✓
Temperature Display	✓
Standby Mode	✓
Auto Closing Dispensing Valve	✓
Dispensing Speed Control	✓
Low Mix Indicator Light & Alarm	✓
Low Temperature Protection	✓
Motor Overload Protection	✓
High Pressure Protection	✓
Defrost & Quick Freeze	✓
Soft Start	✓
Direct Drive Pump (A only)	✓

## AVAILABLE OPTIONS

Water Cooled	✓
Top Air Discharge Chute	✓

• Above specifications are subject to change without notice