



6236-C/6236A-C

SOFT SERVE FREEZER

Single Flavor, Countertop, Digital Control
A: Pump Feed Model

Powerful and Versatile

Single flavor high capacity countertop model for ice cream, frozen yogurt and much more

Fast Freeze Down

Patented high efficiency heat exchanger allows fast freeze down with low energy consumption

Digital Control and Display

Microprocessor control provides access to system settings and additional functions. Digital interface displays critical info as system status, temperatures, dispense count, errors, etc.

Auto Programming

Allows automatic switching of operation modes based on preset schedules

Standby

Maintains product temperature in both mix hopper and freezing cylinder below 4.4°C (40°F) overnight

Hopper Agitator

Maintains product consistency, prevents product separation

Ideal for high capacity outlets to serve ice cream, frozen yogurt, gelato or sorbet. Fully loaded with all standard options. Small footprint saves counter space.



Soft System Start

Slow motor start reduces equipment noise and stress on drive train

Direct Drive Transmission

Eliminates consumable moving parts and increases transmission efficiency

Defrost for Cleaning

Increases efficiency during cleaning by heating frozen product in cylinder

Quick Refreeze

Turn on freeze immediately to freeze down to serving viscosity when quick service is required after long idle period

Self Closing Valve with Speed Control

Automatically prevents product overflow after dispense; Provides flexibility in dispense rate control

Safety Protections

- Low temperature and motor overload shutoffs to protect in the event of cylinder freeze up
- High pressure switch to prevent compressor overheating



6236-C / 6236A-C

SOFT SERVE FREEZER

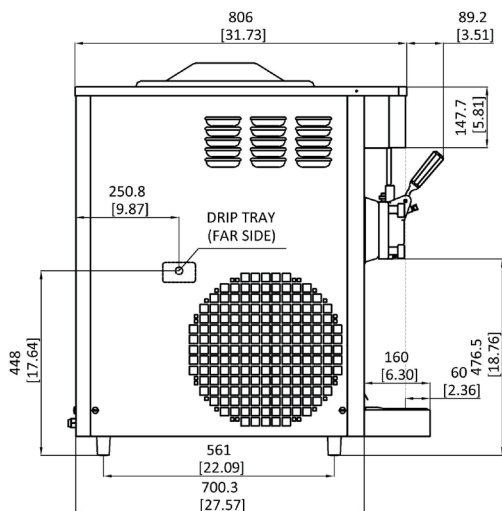
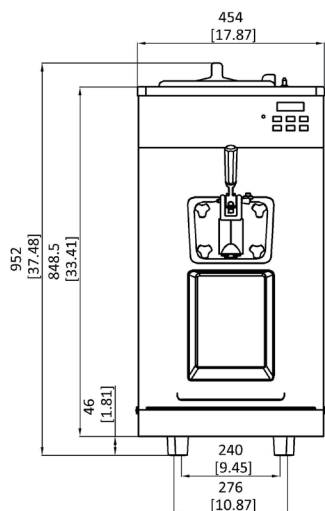

SPECIFICATIONS

Flavors	1
Freezing Cylinders	1 x 3.2 L / 3.4 qt
Mix Hoppers	1 x 19 L (13 L for A)
Output Capacity (80 g)	400 serves/hr
Clearance Requirements	152 mm/6" on left

Weight

	Kg/lb (Gravity)	Kg/lb (Pump)
Net	126 / 278	135 / 298
Shipping	139 / 306	148 / 326

Dimensions

	Net (mm/in)	Shipping (mm/in)
Width	454 / 17.9	520 / 20.5
Depth	700 / 27.6	890 / 35.0
Height	952 / 37.5	1070 / 42.1
Volume	0.50 CBM / 17.49 CBF	

Electrical

	Power (kW)	Total Amps (A)	Fuse (A)
220-240/50/1	2.5	13	16
208-230/60/1	2.8	14	20

FEATURES

Control System	Single, Digital
Refrigerated Hopper	✓
Hopper Agitator	✓
Temperature Display	✓
Standby Mode	✓
Auto Closing Dispensing Valve	✓
Dispensing Speed Control	✓
Low Mix Indicator Light & Alarm	✓
Low Temperature Protection	✓
Motor Overload Protection	✓
High Pressure Protection	✓
Defrost & Quick Freeze	✓
Soft Start	✓
Direct Drive Pump (A only)	✓

AVAILABLE OPTIONS

Water Cooled	✓
Top Air Discharge Chute	✓

• Above specifications are subject to change without notice