



6450-C

FROZEN BEVERAGE FREEZER

Single flavor, Countertop, Gravity feed

Most **Compact & Versatile**
Single flavor counter model for
frozen beverage, smoothies and
milkshakes

Fast Freeze Down

Patented high efficiency heat exchanger allows fast freeze down with low energy consumption

Simple Control, Easy Operation

Simple and intuitive control system makes operation and viscosity adjustment easy, swift and more precise

Low Mix Indicator

Light turns "ON" at low mix to alert operator to add mix

See-through Dispensing Door

Clear dispensing door design makes product more attractive and serves as great marketing tool

Standby & Indicator

Maintains product temperature in both mix hopper and freezing cylinder below 4.4°C (40°F) overnight; Indicator lights up during Standby

Higher capacity solution with greater flexibility to serve larger crowds mocktails frozen drinks including milkshakes



Hopper Agitator

Maintain product consistency and prevent product separation

Self-closing Dispensing Valve

Automatically prevents product overflow after dispense

Safety Protections

- High pressure switch to prevent compressor overheating
- Thermal overload to protect from motor overheating

Light Box (Optional)

- Illuminates advertising cards to attract more business
- Changes color to indicate Low Mix and Standby

One-hand Operated Spinner (Optional)

- Adds ability to blend and offer more varieties of treats
- Allows for multi-tasking one-hand operation that helps increase productivity and reduce serving time



6450-C

FROZEN BEVERAGE FREEZER

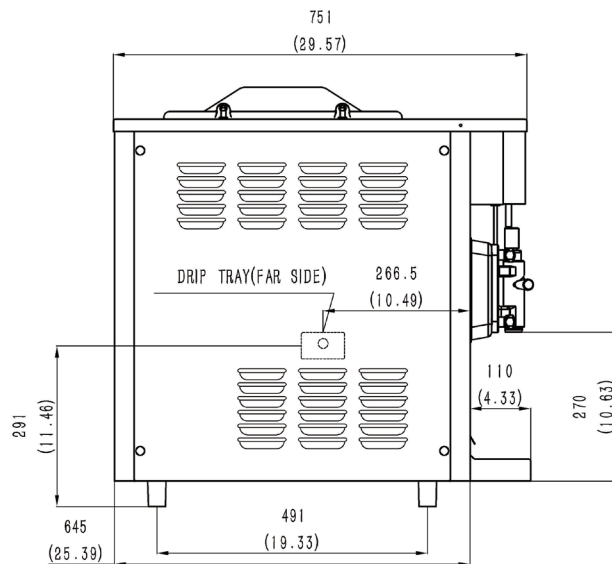
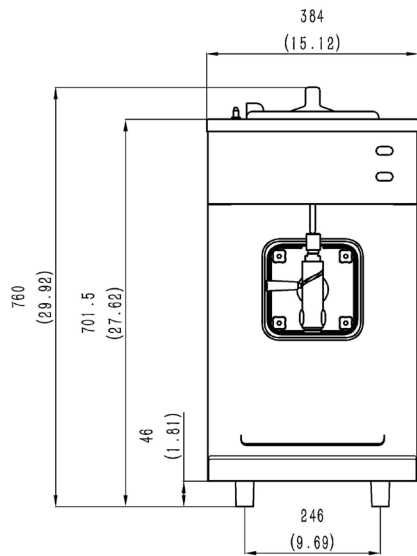

SPECIFICATIONS

Flavors	1
Freezing Cylinders	1 x 3.8L / 4.0qt
Mix Hoppers	1 x 12L / 15.9qt
Output Capacity (250ml)	80 serves/hr
Clearance Requirements	152mm/6" on back

Weight

Kg/lb

Net	199 / 218
Shipping Cylinders	109 / 240
Volume	0.30 CBM / 10.43 CBF

Dimensions

	Net (mm/in)	Shipping (mm/in)
Width	384 / 15.1	420 / 16.5
Depth	645 / 25.4	790 / 31.1
Height	760 / 29.0	890 / 35.0

Electrical

	Fuse	Amps	Power(kW)
220-240/50/1	13	7	1.6
208-230/60/1	15	8	1.6
110-120/60/1	20	14	1.4

FEATURES

Control System	One, Mechanical
Refrigerated Hopper	✓
Hopper Agitator	✓
Standby Mode	✓
Auto Closing Dispensing Valve	✓
Low Mix Indicator Light	✓
Low Mix Indicator Alarm	✓
Standby Indicator Light	✓
High Pressure Protection	✓
Thermal Overload Protection	✓

AVAILABLE OPTIONS

Top Air Discharge Chute	✓
Spinner	✓
Light Box	✓

• Above specifications are subject to change without notice