

# 6455-C

## FROZEN BEVERAGE FREEZER

Two flavor, Countertop, Gravity feed



### Powerful & Versatile

Two flavor countertop model for frozen beverage and smoothies

#### Fast Freeze Down

Patented high efficiency heat exchanger allows fast freeze down with low energy consumption

#### Simple Control, Easy Operation

Simple and intuitive control system makes operation and viscosity adjustment easy, swift and more precise

#### Low Mix Indicator

Light turns "ON" at low mix to alert operator to add mix

#### See-through Dispensing Door

Clear dispensing door design makes product more attractive and serves as great marketing tool

#### Standby & Indicator

Maintains product temperature in both mix hopper and freezing cylinder below 4.4°C (40°F) overnight; Indicator lights up during Standby

Perfect solution for mocktails frozen beverages in bars, restaurants, hospitals, schools and kiosks



#### Hopper Agitator

Maintain product consistency and prevent product separation

#### Self-closing Dispensing Valve

Automatically prevents product overflow after dispense

#### Safety Protections

- High pressure switch to prevent compressor overheating
- Thermal overload to protect from motor overheating

#### Light Box (Optional)

- Illuminates advertising cards to attract more business
- Changes color to indicate Low Mix and Standby

#### One-hand Operated Spinner (Optional)

- Adds ability to blend and offer more varieties of treats
- Allows for multi-tasking one-hand operation that helps increase productivity and reduce serving time



# 6455-C

# FROZEN BEVERAGE FREEZER

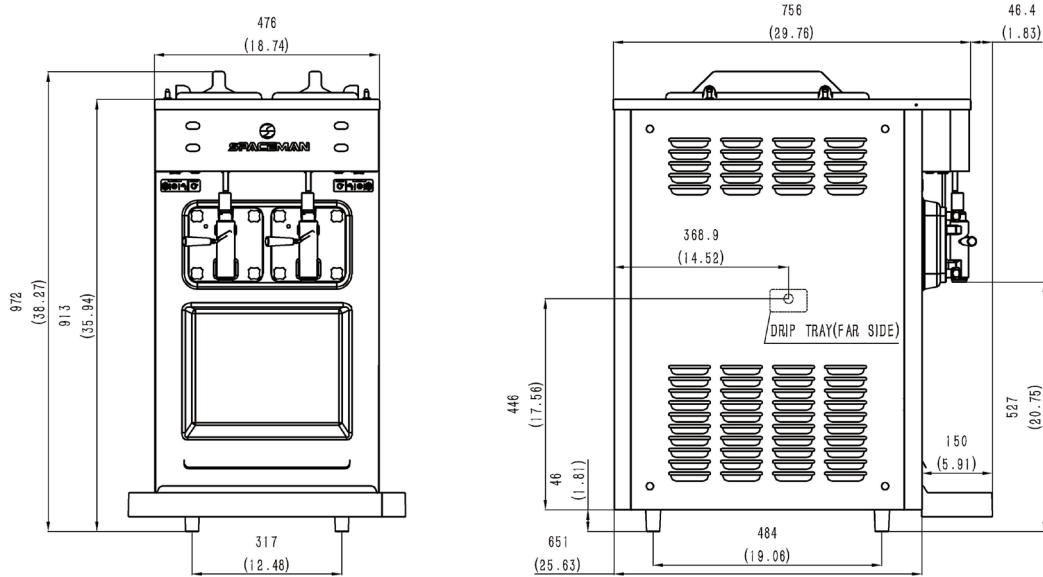

## SPECIFICATIONS

Flavors	2
Freezing Cylinders	2 x 3.8L / 4.0qt
Mix Hoppers	2 x 8.0L / 8.5qt
Output Capacity (250ml)	112 serves/hr
Clearance Requirements	152mm/6" on right

## Weight

## Kg/lb

Net	146 / 322
Shipping Cylinders	166 / 366
Volume	0.54 CBM / 16.01 CBF

## Dimensions

## Net (mm/in)

## Shipping (mm/in)

Width	476 / 18.7	520 / 20.5
Depth	651 / 25.6	800 / 31.5
Height	972 / 38.3	1090 / 42.9

## Electrical

## Fuse

## Amps

## Power(kW)

220-240/50/1	16	12	2.3
208-230/60/1	15	12	2.3

## FEATURES

Control System	Two, Mechanical
Refrigerated Hopper	✓
Hopper Agitator	✓
Standby Mode	✓
Auto Closing Dispensing Valve	✓
Low Mix Indicator Light	✓
Low Mix Indicator Alarm	✓
Standby Indicator Light	✓
High Pressure Protection	✓
Thermal Overload Protection	✓

## AVAILABLE OPTIONS

Top Air Discharge Chute	✓
Spinner	✓
Light Box	✓

• Above specifications are subject to change without notice