



6228B-C 6228AB-C

SOFT SERVE FREEZER

1 Flavor, Countertop, Pasteurization
A: Pump Feed Model

Most **Compact & Powerful**
medium capacity counter model
with **Auto-Pasteurization**
and intelligent control

Auto-Pasteurization

Significantly reduces frequency of cleaning to every 21 days with scheduled daily auto-pasteurization

Digital Control and Display

Microprocessor control provides access to system settings and additional functions. Digital interface displays critical info as system status, temperatures, dispense count, errors, etc.

Operation Logging

Logs every operation and error to provide history and data for easy troubleshooting

Auto Programming

Allows automatic switching of operation modes based on preset schedules

Ideal for any restaurants, convenience stores, dessert stands and delis to serve ice cream and gelato but with desire for significant reduction in labor cost of cleaning.



Hopper Agitator

Maintain product consistency and prevent product separation

Defrost for Cleaning

Increases efficiency during cleaning by heating frozen product in cylinder

Direct Drive Transmission

Eliminates consumable moving parts and increases transmission efficiency

Safety Protections

- Low temperature and motor overload shutoffs to protect in the event of cylinder freeze up
- High pressure switch to prevent compressor overheating

Refresh and Revive

Restore perfect consistency automatically to reduce product waste and labor cost while ensuring food safety

Self Closing Valve with Speed Control

Automatically prevents product overflow after dispense; Provides flexibility in dispense rate control



6228B-C/6228AB-C

SOFT SERVE FREEZER

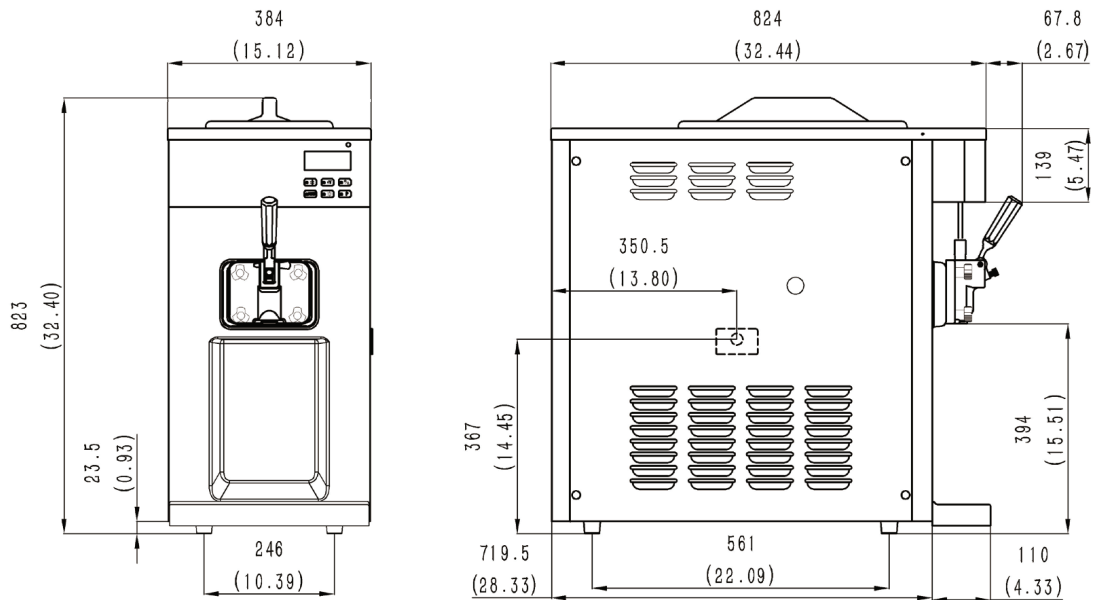

SPECIFICATIONS

Flavors	1
Freezing Cylinders	1 x 1.7L / 1.8qt
Mix Hoppers	1 x 12L (10L for A)
Output Capacity (80 grams)	360 serves/hr
Clearance Requirements	152mm/6" on back

Weight

	Kg/lb (Gravity)	Kg/lb (Pump)
Net	119 / 262	124 / 276
Shipping Cylinders	132 / 291	137 / 305
Volume	0.47 CBM / 16.62 CBF	

Dimensions

	Net (mm/in)	Shipping (mm/in)
Width	384 / 15.1	500 / 19.7
Depth	720 / 28.3	870 / 34.3
Height	823 / 32.4	1080 / 42.5

Electrical

Electrical	Fuse	Amps	Power(kW)
220-240/50/1	25	14	2.8
208-230/60/1	30	15	3.0

FEATURES

Control System	Single, Digital
Refrigerated Hopper	<input checked="" type="checkbox"/>
Hopper Agitator	<input checked="" type="checkbox"/>
Temperature Display	<input checked="" type="checkbox"/>
Standby Mode	<input checked="" type="checkbox"/>
Auto CISOING Dispensing Valve	<input checked="" type="checkbox"/>
Dispensing Speed Control	<input checked="" type="checkbox"/>
Low Mix Indicator Light & Alarm	<input checked="" type="checkbox"/>
Low Temperature Protection	<input checked="" type="checkbox"/>
Motor Overload Protection	<input checked="" type="checkbox"/>
High Pressure Protection	<input checked="" type="checkbox"/>
Defrost & Refresh	<input checked="" type="checkbox"/>
Soft Start	<input checked="" type="checkbox"/>
Direct Drive Pump	<input checked="" type="checkbox"/>
Auto-Pasteurization	<input checked="" type="checkbox"/>

AVAILABLE OPTIONS

Water Cooled	<input checked="" type="checkbox"/>
Top Air Discharge Chute	<input checked="" type="checkbox"/>

• Above specifications are subject to change without notice