



6234-C / 6234A-C

SOFT SERVE FREEZER

Two Flavor, Countertop, Dual Controls
A: Pump Feed Model



Most **Compact & Versatile**
two-flavor countertop model with
independent intelligent controls
for ice cream and frozen yogurt

Fast Freeze Down

Patented high efficiency heat exchanger allows fast freeze down with low energy consumption

Digital Control and Display

Microprocessor control provides access to system settings and additional functions. Digital interface displays critical info as system status, temperatures, dispense count, errors, etc.

Operation Logging

Logs every operation and error to provide history and data for easy troubleshooting

Auto Programming

Allows automatic switching of operation modes based on preset schedules

Hopper Agitator

Maintains product consistency, prevents product separation

Ideal for any restaurants, convenience stores,
dessert stands and delis to serve ice cream and
gelato. Small foot print and low energy
consumption help reduce operating cost.

Soft System Start

Slow motor start reduces equipment noise and stress on drive train

Direct Drive Transmission

Eliminates consumable moving parts and increases transmission efficiency

Defrost for Cleaning

Increases efficiency during cleaning by heating frozen product in cylinder

Quick Freeze

Turn on freeze immediately to freeze down to serving viscosity when quick service is required after long idle period

Self Closing Valve with Speed Control

Automatically prevents product overflow after dispense; Provides flexibility in dispense rate control

Safety Protections

- Low temperature and motor overload shutoffs to protect in the event of cylinder freeze up
- High pressure switch to prevent compressor overheating



6234-C / 6234A-C

SOFT SERVE FREEZER

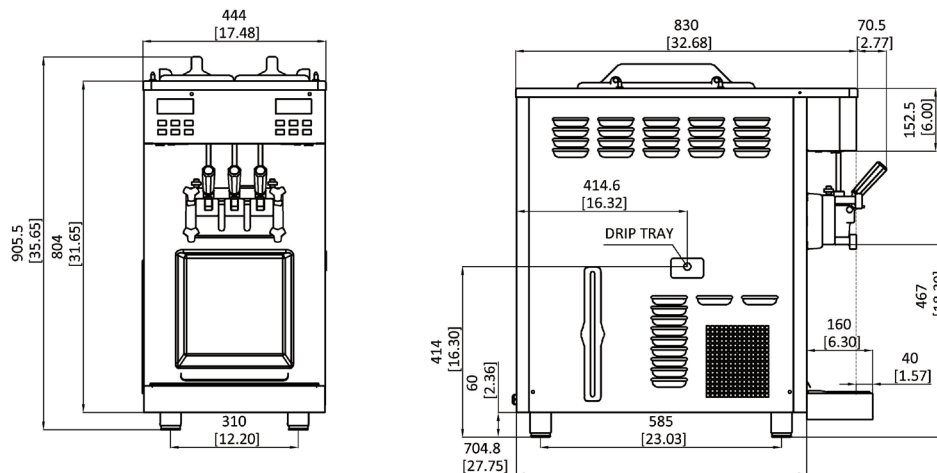

SPECIFICATIONS

Flavors	2 + Twist
Freezing Cylinders	2 x 1.2 L / 1.3 qt
Mix Hoppers	2 x 8 L (5 L for A)
Output Capacity (80 g)	200 serves/hr
Clearance Requirements	152 mm/6" on back

Weight	Kg/lb (Gravity)	Kg/lb (Pump)
Net	128 / 282	140 / 309
Shipping	142 / 313	154 / 340

Dimensions	Net (mm/in)	Shipping (mm/in)
Width	444 / 17.5	530 / 20.9
Depth	705 / 27.8	950 / 37.4
Height	906 / 35.7	1030 / 40.6
Volume	0.52 CBM / 18.31 CBF	

Electrical	Power (kW)	Total Amps (A)	Fuse (A)
220-240/50/1	2.6	12	15
208-230/60/1	2.7	12	15

FEATURES

Control Systems	Double, Digital
Refrigerated Hoppers	<input checked="" type="checkbox"/>
Hopper Agitators	<input checked="" type="checkbox"/>
Temperature Display	<input checked="" type="checkbox"/>
Standby Mode	<input checked="" type="checkbox"/>
Auto Closing Dispensing Valves	<input checked="" type="checkbox"/>
Dispensing Speed Control	<input checked="" type="checkbox"/>
Low Mix Indicator Light & Alarm	<input checked="" type="checkbox"/>
Low Temperature Protection	<input checked="" type="checkbox"/>
Motor Overload Protection	<input checked="" type="checkbox"/>
High Pressure Protection	<input checked="" type="checkbox"/>
Defrost & Quick Freeze	<input checked="" type="checkbox"/>
Soft Start	<input checked="" type="checkbox"/>
Direct Drive Pump (A only)	<input checked="" type="checkbox"/>

AVAILABLE OPTIONS

Top Air Discharge Chute	<input checked="" type="checkbox"/>
-------------------------	-------------------------------------

• Above specifications are subject to change without notice