



6235B-C 6235AB-C

SOFT SERVE FREEZER

2 Flavor, Countertop, Pasteurization
A: Pump Feed Model

Powerful & Versatile

two-flavor table model with
Auto-Pasteurization and
intelligent controls

Auto-Pasteurization

Significantly reduces frequency of cleaning to every 21 days with scheduled daily auto-pasteurization

Digital Control and Display

Microprocessor control provides access to system settings and additional functions. Digital interface displays critical info as system status, temperatures, dispense count, errors, etc.

Operation Logging

Logs every operation and error to provide history and data for easy troubleshooting

Auto Programming

Allows automatic switching of operation modes based on preset schedules

Ideal for medium capacity outlets to serve ice cream and gelato with desire for significant reduction in labor cost of cleaning.



Hopper Agitator

Maintain product consistency and prevent product separation

Defrost for Cleaning

Increases efficiency during cleaning by heating frozen product in cylinder

Safety Protections

- Low temperature and motor overload shutoffs to protect in the event of cylinder freeze up
- High pressure switch to prevent compressor overheating

Quick Refresh

Turn on freeze immediately to freeze down to serving viscosity when quick service is required after long idle period

Self Closing Valve with Speed Control

Automatically prevents product overflow after dispense; Provides flexibility in dispense rate control



6235B-C/6235AB-C

SOFT SERVE FREEZER

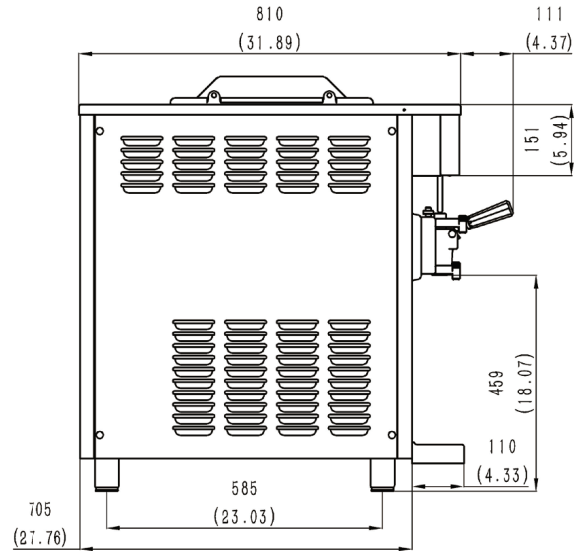
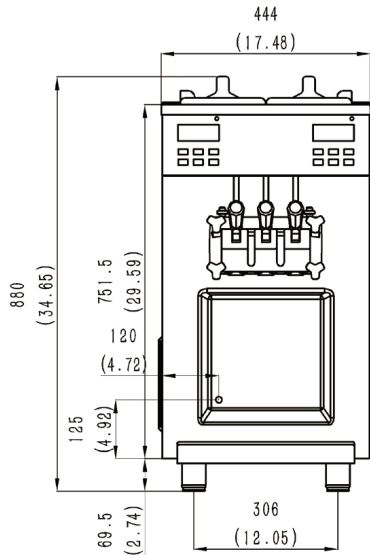

SPECIFICATIONS

Flavors	2 + Twist
Freezing Cylinders	2 x 1.7L / 1.8qt
Mix Hoppers	2 x 8L (5L for A)
Output Capacity (80 grams)	380 serves/hr
Clearance Requirements	152mm/6" on back

Weight	Kg/lb	Kg/lb (Pump)
Net	144 / 317	154 / 340
Shipping Cylinders	160 / 353	170 / 375
Volume	0.48 CBM / 16.78 CBF	

Dimensions	Net (mm/in)	Shipping (mm/in)
Width	444 / 17.5	530 / 20.9
Depth	705 / 27.8	830 / 32.7
Height	880 / 34.6	1080 / 42.5

Electrical	Fuse	Amps	Power(kW)
220-240/50/1	25	15	3.0
208-230/60/1	30	16	3.1

FEATURES

Control System	Double, Digital
Refrigerated Hopper	<input checked="" type="checkbox"/>
Hopper Agitator	<input checked="" type="checkbox"/>
Temperature Display	<input checked="" type="checkbox"/>
Standby Mode	<input checked="" type="checkbox"/>
Auto Closing Dispensing Valve	<input checked="" type="checkbox"/>
Dispensing Speed Control	<input checked="" type="checkbox"/>
Low Mix Indicator Light & Alarm	<input checked="" type="checkbox"/>
Low Temperature Protection	<input checked="" type="checkbox"/>
Motor Overload Protection	<input checked="" type="checkbox"/>
High Pressure Protection	<input checked="" type="checkbox"/>
Defrost & Refresh	<input checked="" type="checkbox"/>
Soft Start	<input checked="" type="checkbox"/>
Auto-Pasteurization	<input checked="" type="checkbox"/>

AVAILABLE OPTIONS

Top Air Discharge Chute	<input checked="" type="checkbox"/>
-------------------------	-------------------------------------

• Above specifications are subject to change without notice